

## Automatic Gearbox – JATCO

### Check and top-up fluid

**WARNING:** Avoid excessive skin contact with mineral oil. Mineral oils remove the natural fats from the skin, leading to dryness, irritation and dermatitis.

1. Position vehicle on ramp.
2. Apply handbrake and position chocks under front and rear wheels.
3. Remove underbelly panel.

 **EXTERIOR FITTINGS, REPAIRS, Panel - underbelly.**

4. Connect TestBook to monitor gearbox fluid temperature.

**CAUTION:** The gearbox fluid level must only be checked when the temperature of the fluid is between 35° and 45°. The reading obtained will be incorrect if the fluid is outside this temperature range.

5. Start engine, move selector lever from 'P' through all gear positions, pausing in each gear position for 2-3 seconds and return to 'P' position.
6. Clean area around level plug.

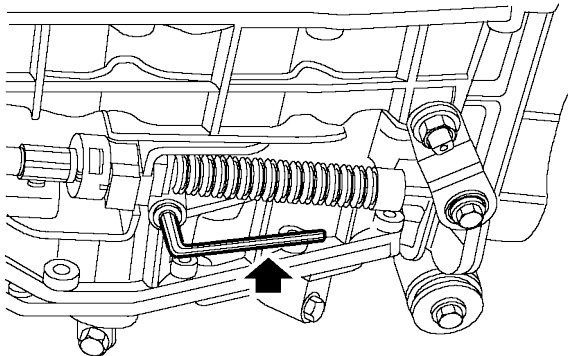

M44 1644

7. With the engine still running, remove level plug using a 5 mm Allen socket and allow any excess fluid to drain off.

**WARNING:** Observe due care when draining gearbox fluid as the fluid can be very hot.

**CAUTION:** There are a number of similar fixings/plugs on the underside of the gearbox. It is imperative that the correct plug is removed prior to checking the level. Removing the wrong fixing/plug could result in internal damage to the gearbox.

8. If no fluid loss is apparent when level plug is removed:

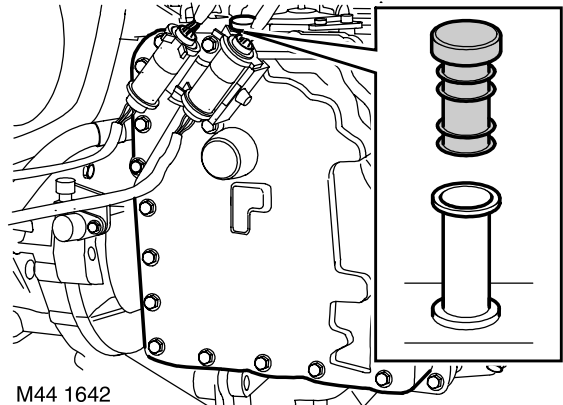

9. Remove filler plug and add fluid until it just runs from level plug aperture.

**When topping up after a new air blast cooler (Td4 hot climates) has been fitted, an extra 420 cc of fluid is required. The fluid must also reach a temperature of 80° C (176° F) to allow the switch on the cooler to open.**

10. Move selector lever from 'P' through each gear position and return to 'P', allowing any excess fluid to drain off.
11. Fit new level plug and tighten to 14 Nm (10 lbf.ft).
12. Clean and fit filler plug.
13. Disconnect TestBook.
14. Fit underbelly panel.

 **EXTERIOR FITTINGS, REPAIRS, Panel - underbelly.**